

PAGE 250-251

DIN 1869 2-3

1692LS - 1693LS (h8)

Ø mm	1~3	3.1~6	6.1~10	10.1~18	18.1~20
tol. D µ	0 / -14	0 / -18	0 / -22	0 / -27	0 / -33

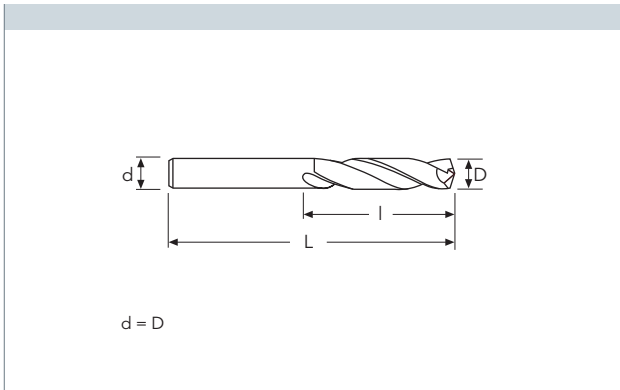

D	I	L	Stock	Stock
mm 3.00	130	190	●	
3.50	145	210	●	
3.50	180	265		●
4.00	150	220	●	
4.00	190	280		●
4.50	160	235	●	
4.50	200	295		●
5.00	170	245	●	
5.00	210	315		●
5.50	180	260	●	
5.50	225	330		●
6.00	180	260	●	
6.00	225	330		●
6.50	190	275	●	
6.50	235	350		●
7.00	200	290	●	
7.00	250	370		●
7.50	200	290	●	
7.50	250	370		●
8.00	210	305	●	
8.00	265	390		●
8.50	210	305	●	
8.50	265	390		●
9.00	220	320	●	
9.00	280	410		●
9.50	220	320	●	
9.50	280	410		●
10.00	235	340	●	
10.00	295	430		●
10.50	235	340	●	
10.50	295	430		●
11.00	250	365	●	
11.00	310	455		●
12.00	260	375	●	
12.00	330	480		●

● stock standard ○ non-standard stock ■ stock exhaustion

TYPHOON
C-SD-TA
LFTA
SUTA
HSS-HSS/CO DRILLS
UH RED
MEX ORANGE
HF EVO
MEF ENDLESS
ALU
MDC
G2
MDTA
ULTRA MILLS
HSS/CO
CARBIDE BURRS
PARAMETERS