

n **Vf**
PAGE 301-302

DIN 844

WS3 - TAWS3 (e8)

Ø mm	1-3	3.5-6	6.5-10	10.5-18	19-30	32-40
tol. D µ	-14 / -28	-20 / -38	-25 / -47	-32 / -59	-40 / -73	-50 / -89

TAWSH3

Ø mm	1-3	3.5-6	6.5-10	10.5-18	19-30	32-40
tol. D µ		0 / +48	0 / +58	0 / +70	0 / +84	

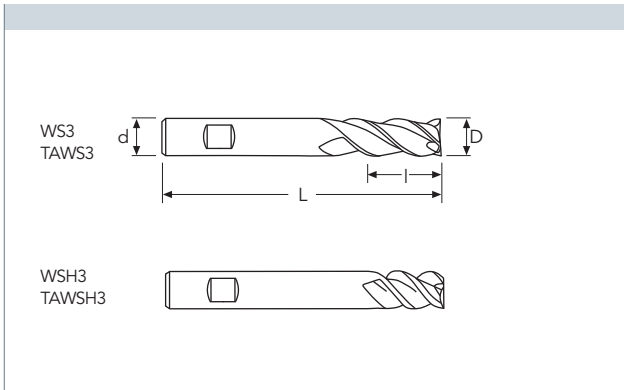

HSS/Co BR	HSS/Co PV200	HSS/Co PV200
N	N	N

D	d(h6)	l	L	Stock	Stock	Stock
mm 1	6	3	47	●	○	
1.5	6	7	51	●	○	
2	6	7	51	●	●	
2.5	6	8	52	●	●	
3	6	8	52	●	●	
3.5	6	10	54	●	●	
4	6	11	55	●	●	
4.5	6	11	55	●	●	
5	6	13	57	●	●	
5.5	6	13	57	●	●	
6	6	13	57	●	●	●
6.5	10	16	66	●	●	
7	10	16	66	●	●	
8	10	19	69	●	●	●
8.5	10	19	69	●	●	
9	10	19	69	●	●	
10	10	22	72	●	●	●
11	12	22	79	●	●	
12	12	26	83	●	●	●
13	12	26	83	●	●	
14	12	26	83	●	●	●
15	12	26	83	●	●	
16	16	32	92	●	●	●
18	16	32	92	●	●	●
20	20	38	104	●	●	●
22	20	38	104	●	●	
25	25	45	121	●	●	
30	25	45	121	●	○	
32	32	53	133	●	○	

● stock standard ○ non-standard stock ■ stock exhaustion

- TYPHOON
- C-SD-TA
- LFTA
- SUTA
- HSS-HSS/CO DRILLS
- UH RED
- MEX ORANGE
- HF EVO
- MEF ENDLESS
- ALU
- MDC
- G2
- MDTA
- ULTRA MILLS
- HSS/CO
- CARBIDE BURRS
- PARAMETERS