



GB205 - G2CS2

Ø mm	-6	6.5~12	13~20
tol. D µ	0 / -20	0 / -25	0 / -30

G2210 - G2211 - G2212 - G2213

Ø mm	-6	6.5~12	13~20
tol. D µ	0 / -30	0 / -35	0 / -40

GB205 G2CS2 G2210 G2211 G2212 G2213

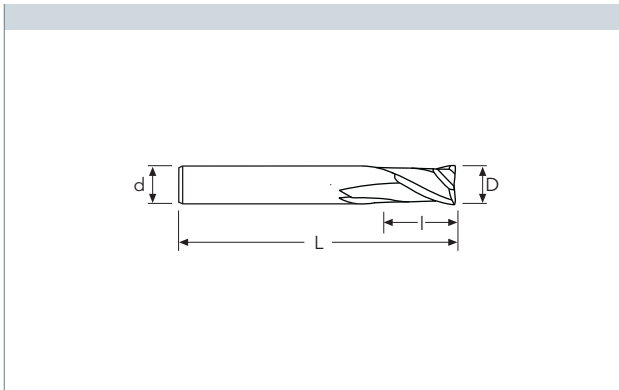
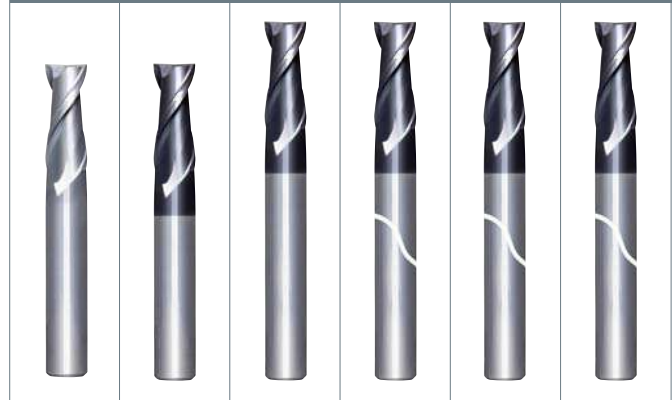

MG	MG	MG	MG	MG	MG
BR	PV200	PV200	PV200	PV200	PV200
N	N	N	N	N	N

D	d	l	L	Stock	Stock	Stock	Stock	Stock	Stock
mm 12	12	50	150						
14	14	26	83		●			●	
16	16	32	92		●				
16	16	70	150					●	
16	16	40	200						○
18	20	40	100		●				
18	20	80	150					○	
20	20	40	100		●				
20	20	80	150					○	
20	20	40	200						○

● stock standard ○ non-standard stock ■ stock exhaustion

- TYPHOON
- C-SD-TA
- LFTA
- SUTA
- HSS-HSS/CO DRILLS
- UH RED
- MEX ORANGE
- HF EVO
- MEF ENDLESS
- ALU
- MDC
- G2
- MDTA
- ULTRA MILLS
- HSS/CO
- CARBIDE BURRS
- PARAMETERS